

Full Flow Swivel Banjos

Part # See list of variations on this page

Assembly Instructions | © Nuke Performance AB 2023

For more information visit : www.nukeperformance.com

- 1** Stainless steel C-clip
- 2** Full Flow banjo top housing, available in different versions
AN-6 Male, AN-8 Male, AN-10 Male, AN-6 Female
- 3** Viton O-ring, same for all versions
Part # 7100-01-103
- 4** Viton O-ring, same for all versions
Part # 7100-01-102
- 5** Full Flow banjo bolt, available in different versions
AN-6 ORB, AN-8 ORB, AN-10 ORB, AN-8 3/4 UNF, 3/8 NPT
- 6** Viton O-ring, available in different versions *
AN-8 (3/4 UNF) Part # 700-10-101
AN-6 ORB Part # 700-20-102
AN-8 ORB Part # 700-20-103
AN-10 ORB Part # 700-20-104
* Not used on 3/8 NPT version

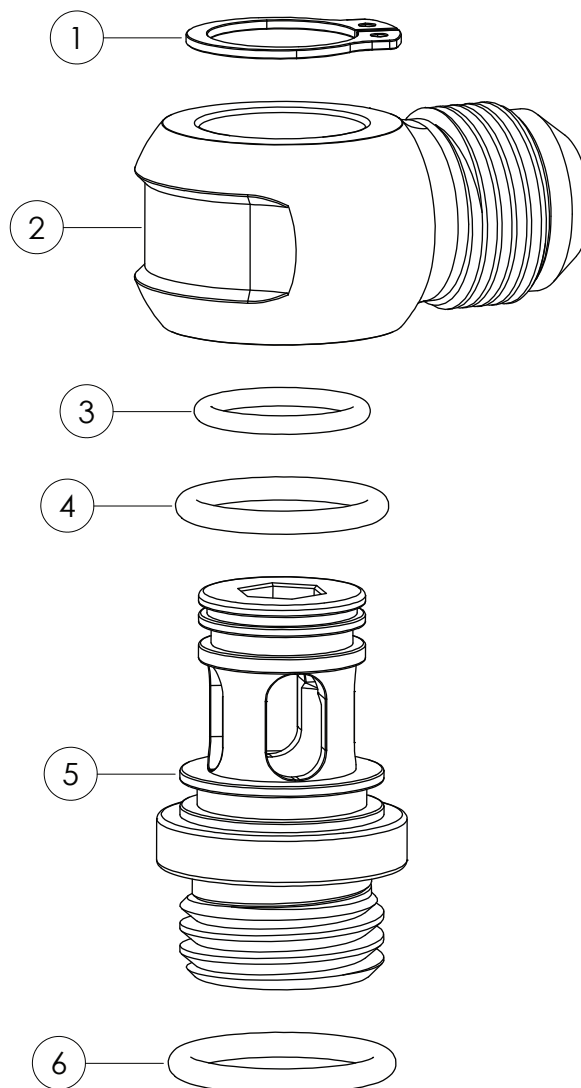

Nuke Performance Full Flow Swivel Banjo Fitting versions

For more information about available options, visit our product page on our website.

Nuke Performance : www.nukeperformance.com

AN-6 ORB to AN-6 Male Full Flow Banjo	710-01-101	AN-8 (3/4 UNF) to AN-10 Male Full Flow Banjo	710-01-115
AN-6 ORB to AN-8 Male Full Flow Banjo	710-01-102	AN-8 (3/4 UNF) to AN-6 Female Full Flow Banjo	710-01-116
AN-6 ORB to AN-10 Male Full Flow Banjo	710-01-103	AN-10 ORB to AN-6 Male Full Flow Banjo	710-01-109
AN-6 ORB to AN-6 Female Full Flow Banjo	710-01-104	AN-10 ORB to AN-8 Male Full Flow Banjo	710-01-110
AN-8 ORB to AN-6 Male Full Flow Banjo	710-01-105	AN-10 ORB to AN-10 Male Full Flow Banjo	710-01-111
AN-8 ORB to AN-8 Male Full Flow Banjo	710-01-106	AN-10 ORB to AN-6 Female Full Flow Banjo	710-01-112
AN-8 ORB to AN-10 Male Full Flow Banjo	710-01-107	3/8 NPT to AN-6 Male Full Flow Banjo	710-01-117
AN-8 ORB to AN-6 Female Full Flow Banjo	710-01-108	3/8 NPT to AN-8 Male Full Flow Banjo	710-01-118
AN-8 (3/4 UNF) to AN-6 Male Full Flow Banjo	710-01-113	3/8 NPT to AN-10 Male Full Flow Banjo	710-01-119
AN-8 (3/4 UNF) to AN-8 Male Full Flow Banjo	710-01-114	3/8 NPT to AN-6 Female Full Flow Banjo	710-01-120

Nuke Performance Full Flow Swivel Banjo Fitting specifications

For more information about specifications, visit our product page on our website.

Nuke Performance : www.nukeperformance.com

Bolt thread (clear part)	AN6 / 8 / 10 ORB, AN8 (3/4 UNF), 3/8 NPT	Diameter bolt (clear part)	27mm (1.06")
Outlet thread (black part)	AN6, AN8, AN10, AN6 Female	Diameter banjo (black part)	34mm (1.34")
Swivel rotation	360 degree, also when it is installed	Height, when installed	30mm (1.18")
Compatibility	Gasoline, Ethanol, Methanol, Diesel, Coolant, Air	O-ring material	Viton, FPM



INCORRECT INSTALLATION CAN CAUSE SERIOUS DAMAGE TO THE PRODUCT AND VEHICLE. AS A RESULT, ACCIDENTS, PROPERTY DAMAGE, AND PERSONAL INJURY ARE POSSIBLE. INSTALLATION MAY ONLY BE CARRIED OUT BY EXPERTS. MAKE SURE TO ALWAYS USE ALL NECESSARY SAFETY EQUIPMENT. THE MANUFACTURER IS NOT LIABLE FOR DAMAGE CAUSED BY IMPROPER INSTALLATION.



Information:

Design combined with top quality performance.
For more information about the products and retailers visit
www.nukeperformance.com

nuke
PERFORMANCE