

FPR100m

AN-8 Fuel Pressure Regulator

300-02-203

Assembly Instructions | © Nuke Performance AB 2021

For more information visit : www.nukeperformance.com

- 1 Stainless steel M10 adjustment nut
- 2 Stainless steel M10x40 hex adjustment bolt
- 3 Stainless steel M10 washer
- 4 Viton O-ring 10.5x1.8 for adjustment bolt
- 5 Stainless steel ball bearing ball
- 6 Stainless steel MC6S M6x12 bolt
- Bolt tightening torque 8.0 Nm (70.0 in/lbs)
- 7 Billet aluminum top housing
- 8 1/16" NPT to 5mm Barb male fitting for vacuum
- 9 Stainless steel top spring seat
- 10 Stainless steel regulator spring
- 11 Stainless steel bracket, mounting point cc 55mm
- 12 Fibre-reinforced nitrile membrane 46mm
- 13 1/8" NPT plug for pressure gauge/sensor
- 14 Billet aluminum bottom housing
- 15 Stainless steel M5x5 MF6S bolt

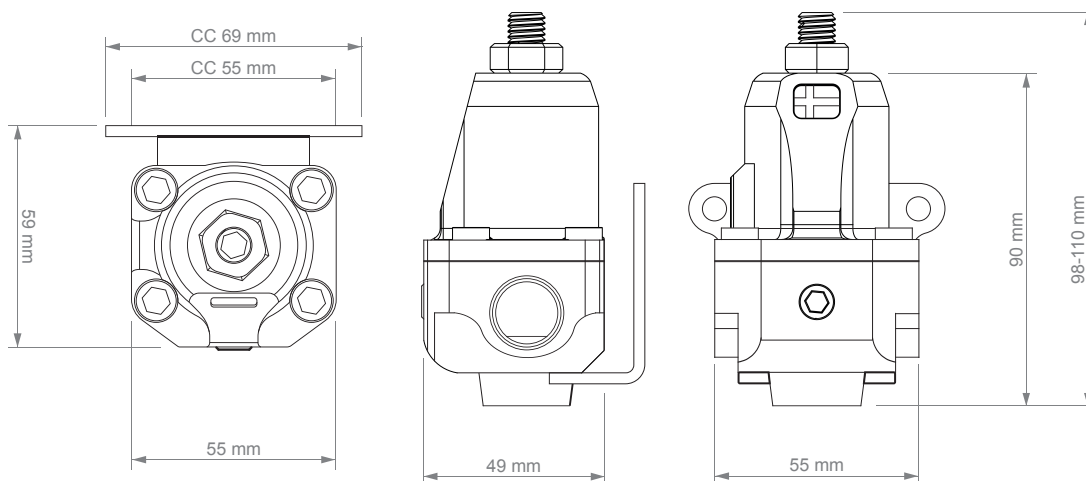
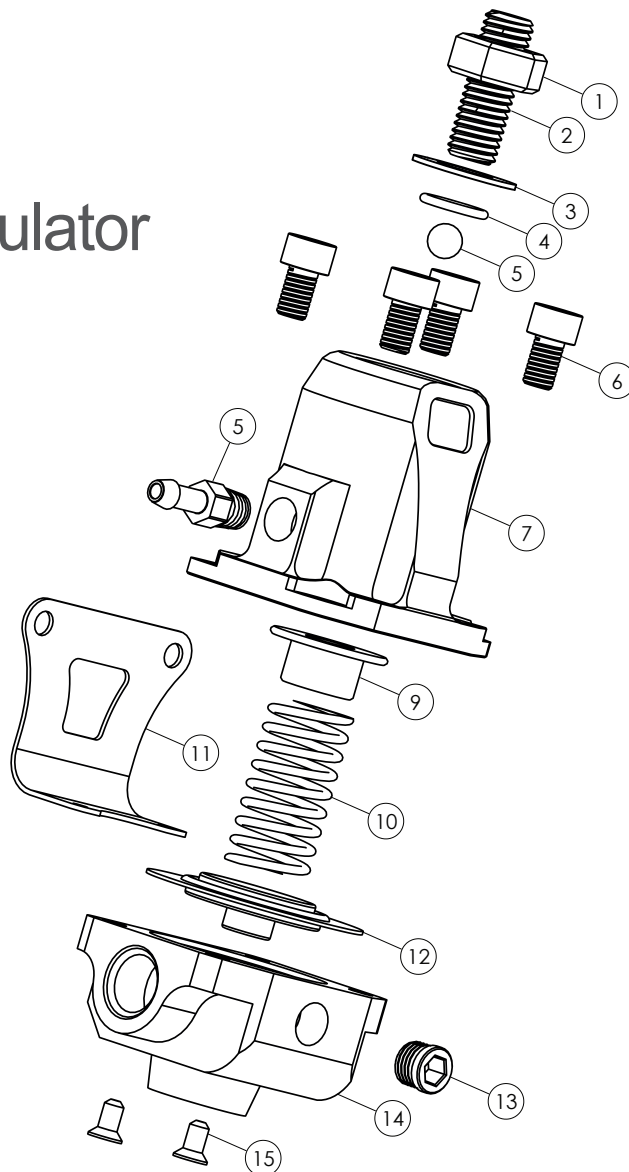

Nuke Performance FPR100m specifications

For more information about specifications, visit our product page on our website.

Nuke Performance : www.nukeperformance.com



Pressure range	2 - 7 BAR (30 - 100 PSI)	Vacuum reference port	1/16" NPT
Boost reference	1:1	Diaphragm	46mm Fibre-nitrile diaphragm
Horsepower rating	1200 HP	Height	98-110mm (3.85-4.33")*
Free fuel flow rating	1000 LPH	Width	55mm (2.16")
Fuel compatibility	Gasoline, Petrol, Methanol, Ethanol	Depth	49mm (1.93")
Inlet thread	Dual AN-8 ORB	Weight	427g (15.06oz)
Outlet thread	Single AN-8 ORB	Ball-Bearing adjustment	≈0.14 BAR (≈2 PSI) / turn
Fuel pressure gauge port	1/8" NPT		* depending on set pressure



INCORRECT INSTALLATION CAN CAUSE SERIOUS DAMAGE TO THE PRODUCT AND VEHICLE. AS A RESULT, ACCIDENTS, PROPERTY DAMAGE, AND PERSONAL INJURY ARE POSSIBLE. INSTALLATION MAY ONLY BE CARRIED OUT BY EXPERTS. MAKE SURE TO ALWAYS USE ALL NECESSARY SAFETY EQUIPMENT. THE MANUFACTURER IS NOT LIABLE FOR DAMAGE CAUSED BY IMPROPER INSTALLATION.



Information:

Design combined with top quality performance.
For more information about the products and retailers visit www.nukeperformance.com

nuke
performance